



ACTIVITY 8

Preparing for the Mission



Overview

By reflecting on their experiences in the module, students articulate questions, pinpoint specific information they would like to obtain and develop an on-going connection with the upcoming Mars missions. Students create a list of questions that have arisen during their work. They then read about the instruments on the *Pathfinder* and *Mars Global Surveyor* and relate the information these instruments will provide with their questions. Finally, students create a calendar for the missions and consider how they will access the information returned by the probes.

Content Goals

- The *Mars Pathfinder* and the *Mars Global Surveyor* have specific mission objectives and a selection of instruments to help achieve those objectives.
- The instruments and investigations arise out of questions people have about Mars, and students are fully capable of generating questions worthy of future study.
- The *Mars Pathfinder* and the *Mars Global Surveyor* missions have specific timetables, and students can follow the progress of each mission in a number of ways.

Skill Goals

- *Identifying* questions that really interest students.
- *Devising* a plan for answering those questions.

Prerequisites

Completion of the Great Martian Floods and the Pathfinder Landing Site module.

Possible Misconceptions

- All space probes have the same basic design and instruments.
Ask: Do you think Voyager, Magellan or Galileo had any of these instruments?
- Robotic space exploration is inferior to manned space travel.
Ask: What would have to be changed in order to have a human collect this information?
- Space missions are sent up all the time.
Ask: How often are space missions launched? What prevents NASA from launching as many missions as it wants? How long can scientists find interesting information in a set of images? Do you think that people assume that there are lots of missions because we see a lot of pictures from space these days?

Materials

Calendar of the missions, length of paper to make a timeline.

Preparation

Obtain a computer with Web access to visit some of the mission-related sites.

Time

1 class period

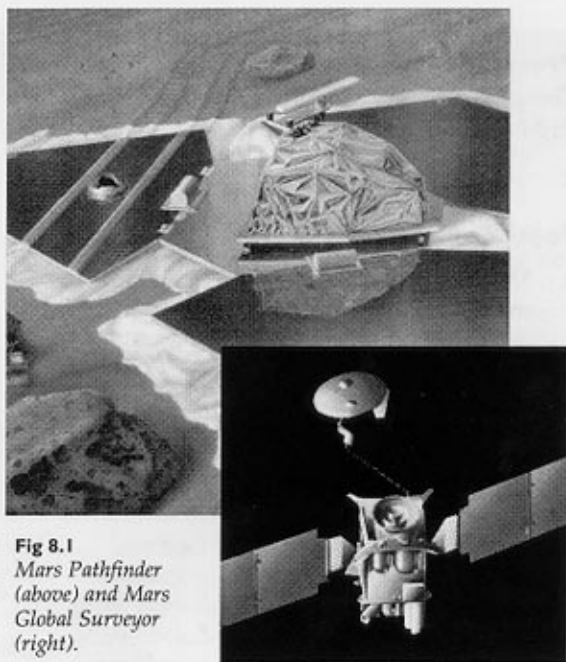

Fig 8.1
Mars Pathfinder
(above) and Mars
Global Surveyor
(right).

At the end of 1996, NASA launched two missions to Mars, the *Mars Pathfinder* and the *Mars Global Surveyor* (MGS) (Fig. 8.1). MGS will study Mars from orbit 400 km (250 mi) above the surface. It was launched in November of 1996, will arrive in September of 1997, and will begin a two-year mapping mission of Mars in March of 1998. MGS has three cameras with resolutions as high as 3 m (10 feet). This compares to the highest resolution images from *Viking* of 20 m (65 feet). Other MGS instruments include:

- a magnetometer/electron reflectometer to study the planet's magnetic field;
- a radio system to study Mars's gravity field and sub-surface mass distribution;
- a laser altimeter to study the planet's surface topography and its overall shape;
- a thermal emission spectrometer to study the heat coming from the surface and atmosphere. This information will enable scientists to create weather maps and identify the size and composition of surface materials.

The *Mars Pathfinder* mission is primarily an engineering demonstration of key technologies and concepts for eventual use in future missions to Mars employing scientific landers. *Pathfinder* also delivers science instruments to the Martian surface to investigate:

- the structure of the Martian atmosphere;
- the weather and meteorology on the surface (wind velocity, pressure and temperature);
- the surface geology;
- the form, structure and composition of Martian rocks and soil.

Pathfinder's flight system has three main parts: the cruise stage (6-7 months), the deceleration systems and the lander. The lander contains all the science instruments and a rover, named *Sojourner* (Fig 8.2). *Sojourner*, the free-ranging surface rover, will be used to conduct experiments and deploy instruments. Upon landing, the primary data-taking phase begins and continues for 30 Martian days or sols (24.6 hours). During this time, *Sojourner* will be deployed and operate for at least seven sols. If the lander and rover continue to perform well at the end of this period, the lander may continue to operate for up to one Martian year, and the rover for up to 30 sols.

To learn more about the Mars Exploration Program, explore the following Web pages:

Mars Global Surveyor:	http://mgs-www.jpl.nasa.gov/
Mars Pathfinder:	http://mpfwww.jpl.nasa.gov
Jet Propulsion Laboratory	http://www.jpl.nasa.gov/

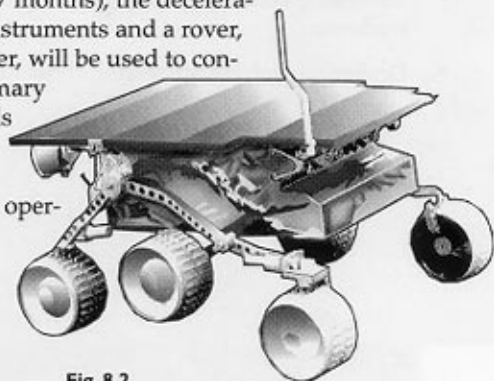

Fig. 8.2
The Mars Pathfinder rover, *Sojourner*.

PROCEDURE

- Have students reflect on their modeling, image analysis and experimental work and generate a list of questions. What have they wondered about during the module? What struck them as particularly interesting? What additional information do they wish they had? Which features they would like to see in more detail? Why? Questions might include: Are the rocks at the *Viking* landing site erratics? What is the source of the water? Are there wave-cut shore lines? Ripple marks? Scablands? Gravel and sand bars?
- Have students read about the instruments on the *Pathfinder* and *MGS*. (See both the material included with this activity and the descriptions in the *Getting Started* module.)
- Review the missions, noting especially that *MGS* will orbit Mars and collect data for at least a full Martian year (two Earth years) and that the *Pathfinder* lander can operate for up to one Martian year. Review the instruments that especially pertain to studying the Martian floods: the cameras, Thermal Emission Spectrometer (chemical composition), Laser Altimeter (altitude), and APXS (surface geology and chemical composition). Which of their questions can each instrument help answer? What instruments would they like to see on a future mission? Could they imagine themselves designing or operating such an instrument?
Planetary missions take years of preparation. Some of the scientists and engineers have been preparing for the missions for over ten years.
- Show students the calendar for the missions. Ask them:
 - where they expect they might be at these times;
 - how might they access information from the instruments or about the mission.
Newspapers, magazines, the Web, television, radio, friends.
- Have each student devise a plan that outlines how he or she might obtain answers to his or her questions.

6. Put a timeline on the wall showing the months from now until June, 1998. Mark the events listed on the calendar to follow the progress of the missions.

Mars Pathfinder

	JAN	FEB	MAR	APR	MAY	JUN	JUL	AUG	SEP	OCT	NOV	DEC
1996												Launch
1997			Voyage to Mars				Arrival & Primary Missions	Possible extended Lander Mission				

Mars Global Surveyor

	JAN	FEB	MAR	APR	MAY	JUN	JUL	AUG	SEP	OCT	NOV	DEC
1996												Launch
1997			Voyage to Mars						Stabilize Orbit			
1998	Stabilize Orbit	Mission										
1999	Mission											
2000	Possible extended Mission											

- Explain that approximately every week a new set of images from *Pathfinder* and *MGS* will be posted on the World Wide Web. Your students will be able to use computers at school or at home to access these images. The released images will include close-up images of the flood channels as well as many other parts of Mars. Once this release of images begins, your students can build on the questions and excitement these images raise and extend their studies of Mars. Ultimately, students may even be able to request that images be taken of a site they are interested in studying.

INSTRUMENTS ON MARS GLOBAL SURVEYOR THAT PERTAIN TO THIS MODULE

(based on an article by Mike Malin, Principal Investigator on the MGS camera)

In November 1996, NASA launched the *Mars Global Surveyor* (MGS). After a ten-month cruise, the spacecraft will enter an elliptical orbit around Mars. For about six months thereafter, it will gently dip into the upper portions of the Martian atmosphere, using atmospheric drag to slowly shrink its orbit. In mid-March of 1998, it will begin its two-year mapping mission 400 km (250 mi) above the Martian surface.

Particularly relevant to the study of Ares Vallis are the three cameras. MGS has two low-resolution cameras capable of recognizing features 500 m (about 1,600 ft) across and one narrow-angle camera (Fig. 8.3) able to see things as small as 3 m (10 ft) across. The low resolution cameras will make daily maps enabling scientists to see things such as surface features and dust and ice clouds. The narrow-angle camera, which can see boulders the size of cars, will be used to search for traces of beaches and glaciers, the effects of water seeping from canyon walls, and layers in polar deposits that reflect climate changes. It will also look for the two *Viking* landers and the *Pathfinder* lander. If successful, these pictures will finally tie together the view from Mars' surface and that seen from orbit. In contrast, the cameras on the *Viking* orbiter photographed only about 15% of Mars with a resolution of 100 meters (305 feet), and only two tenths of one percent of the Martian surface was mapped in sufficient detail to show objects measuring 20 m (65 feet) in diameter.

Also relevant to the study of the Martian floods are two other instruments on the MGS (there are a total of five instruments on the MGS). The laser altimeter (Fig. 8.4) will tell scientists a great deal about the topography of Mars. Among other things, the altimeter will measure the:

- depths of craters
- heights of volcanoes
- steepness of cliffs
- slopes of water-carved canyons.

It will also be used in conjunction with other instruments to help determine the global shape of Mars and the thickness and strength of the planet's crust.

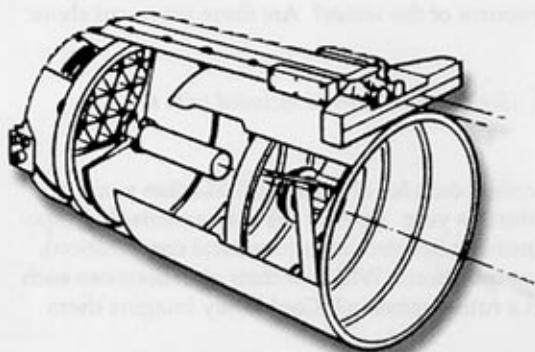

Fig. 8.3
A camera from the Mars Global Surveyor mission.

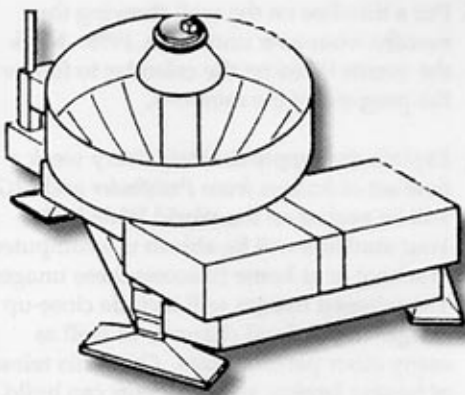

Fig. 8.4
The Laser Altimeter from the Mars Global Surveyor mission.

The Thermal Emission Spectrometer (TES) (Fig. 8.5) measures the amount of heat coming from the surface and atmosphere at many different wavelengths. TES will determine:

- atmospheric temperature and pressure at several different altitudes;
- the concentration of dust both in layers on the ground and spread throughout the atmosphere;
- the size of particles on the surface, from dust grains to bedrock. It does this by comparing the temperature during the day with that observed at night (the same effect that causes beach sand to be very hot during the day and to be cool at night). The sizes of particles on the surface help scientists tell how the particles were moved (e.g., by wind, water or other processes);
- what the Martian rocks, sand and dust are made of, and in what proportions. TES will be able to discriminate volcanic rocks similar to those found in Hawaii (basaltic) from rocks and ash similar to those erupted by Mount Saint Helens (rhyolitic). It will search for minerals left behind as possible lakes or other bodies of water dried up, and for minerals that formed when the atmosphere was potentially thicker and wetter than it is today.

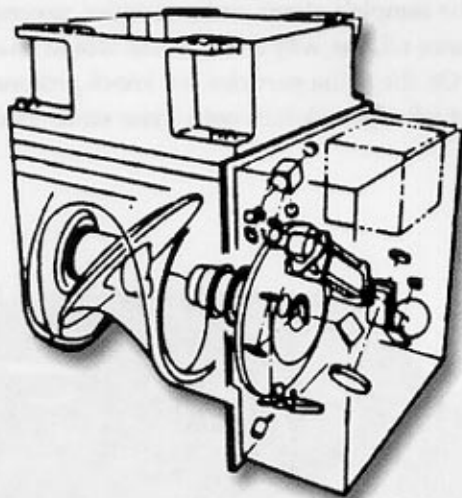

Fig. 8.5
The Thermal Emission Spectrometer from the Mars Global Surveyor mission.

INSTRUMENTS ON THE PATHFINDER THAT PERTAIN TO THIS MODULE

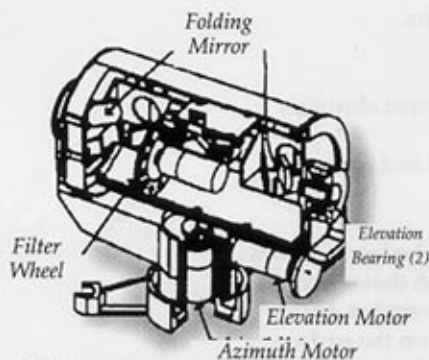

Fig. 8.6
Cameras on the Mars Pathfinder.

The imaging system on the *Pathfinder* (Fig. 8.6) can look at the landing site stereoscopically, and in black-and-white and color modes. Each of the imager's two cameras has 24 filters that were carefully selected to allow the determination of certain atmospheric and surface properties. For example, a band at about 1.0 microns will allow determination of the presence of pyroxene, a key mineral expected to be present in the rocks.

Another instrument carried on the rover is the Alpha Proton X-ray Spectrometer (APXS) (Fig. 8.7). The TV in your home is a bit like the APXS. Though you may not realize it, that bump on the back of your TV is a gun aimed at the screen. But rather than shooting bullets, the gun shoots tiny particles called electrons. When the electrons hit the phosphor powder on the back of the glass screen, it causes the powder to glow. By controlling the stream of electrons coming out of the gun and making different sections of the screen glow brightly, dimly

or not at all, a TV can display an infinite variety of images.

The APXS uses radioactive cesium as a source of particles to shoot out its gun. These particles, called alpha particles, are made up of two protons and two neutrons (i.e., a helium nucleus). The gun shoots a stream of alpha particles at rock or soil sample. When the alpha particles hit the sample's atoms and molecules, several things can happen. First, the alpha particles can be deflected and bounce off, the way a tennis ball would change the direction of its flight if it hit part of an object such as a bicycle. Or, the alpha particles can knock protons off the sample's atoms and molecules the way sand grains are scattered when a rock falls onto some sand. Finally, the alpha particles can energize the sample's atoms and cause them to emit energy in the form of x-rays. Think of a stone thrown into a pond. The waves spreading out from where the rock landed represent the x-ray energy.

The APXS has detectors that records all three of these effects that might be emitted by a sample. By bombarding elements such as carbon and iron with alpha particles on Earth, scientists know the pattern each element makes. By comparing the patterns they see in the APXS's detector with the patterns they know from their tests on Earth, scientists can tell the composition of the rock and soil samples. Elements such as carbon, oxygen, magnesium, aluminum, silicon, calcium, potassium, iron and nickel can be identified.

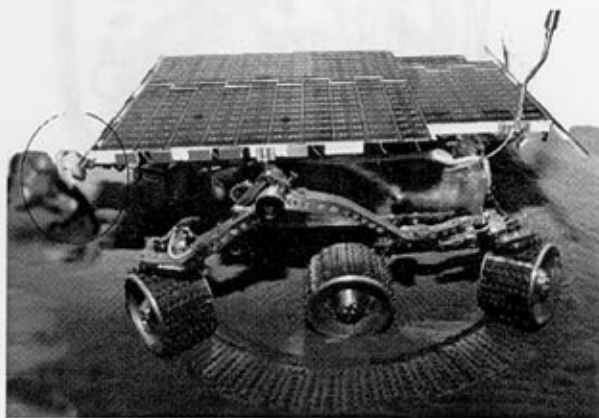

Fig. 8.7
Pathfinder sampling a rock with the APXS.

MATERIALS FOR THE GREAT MARTIAN FLOODS MODULE

- One Teacher Handbook and student image sets (one per two students recommended)

Mars Exploration Education and
Public Outreach Program
Jet Propulsion Laboratory
4800 Oak Grove Drive
Pasadena, CA 91109
(818) 354-6111

- *Two Faces of Mars poster*, Item # 1338, \$15.00

Spaceshots
33950 Barnby Rd.
Acton, CA 93510
(800) 272-2779 (phone)
(805) 268-1653 (fax)

- *An Explorer's Guide to Mars poster*, Item # 505, \$6.00,

The Planetary Society
65 North Catalina Avenue
Pasadena, CA 91106-2301
(818) 793-1675 (phone)
(800) 966-7827 (fax)

- *The Great Floods, Cataclysms of the Ice Age video*, \$14.95

Northwest Interpretive Association
Coulee Dam National Recreation Area
1008 Crest Drive
Coulee Dam, WA 99116
(509) 633-9199

- *The Channeled Scablands of Eastern Washington booklet* by Weiss & Newman, \$2.50

Northwest Interpretive Association,
see above address.

- *Cataclysms on the Columbia book* by J. Eliot and M. Burns, \$14.95

Northwest Interpretive Association,
see above address.

RESOURCES

Posters

Mars Pathfinder and *Mars Global Surveyor*,
(while supplies last)

Mars Exploration Education and
Public Outreach Program
Jet Propulsion Laboratory
4800 Oak Grove Drive
Pasadena, CA 91109
(818) 354-6111

Video

Mars Pathfinder, (while supplies last)

Mars Exploration Education and
Public Outreach Program, see above address.

CD-ROMs

Mars Navigator Interactive Multimedia CD-ROM,
describes JPL's *Mars Global Surveyor* and
Mars Pathfinder missions (while supplies last)

Mars Exploration Education and Public Outreach
Program, see above address.

The Mars Educational Multimedia CD-ROM,
provides a Mars atlas, Mars-based lesson plans,
descriptive information about Mars, image pro-
cessing software to extract information from the
images in the Mars atlas and from new images
acquired by future orbiter and lander missions.

The Center for Mars Exploration,
Mail Stop 245-1
NASA Ames Space Science Division
Moffett Field, CA 94035-1000
(415) 604-4217
Recommended ordering procedure:
<http://cmex-www.arc.nasa.gov>

Web Sites

Mars Global Surveyor: <http://mgs-www.jpl.nasa.gov/>

Mars Pathfinder: <http://mpfwww.jpl.nasa.gov>

Jet Propulsion Laboratory: <http://www.jpl.nasa.gov/>

Center for Mars Exploration:
<http://cmex-www.arc.nasa.gov/>

The Planetary Society: <http://planetary.org/tps/>

Arizona Mars K-12 Education Program
http://esther.la.asu.edu/asu_tes/

Periodicals

The Planetary Report

The Planetary Society
65 North Catalina Avenue
Pasadena, CA 91106-2301
(818) 793-5100 (phone)
(818) 793-5528 (fax)

Mars Underground News

The Planetary Society, see above address

Recommended Maps and Photomosaics of Selected Martian Features,

General:

Map of Olympus Mons to Ares Vallis I-1618
Map of Eastern Valles Marineris to Ares Vallis I-1448
Topographic Map of Mars (1:25,000,000) (1 map) I-961
Topographic Map of Mars
(1:15,000,000) (3 maps) I-2160

Volcanoes:

Photomosaic of Olympus Mons I-1379
Map and photomosaic of Tharsis volcanoes I-1922

Canyons:

Map of Central Valles Marineris I-1253
Photomosaic of entire Valles Marineris I-1206,
I-1207, I-1208, I-1184, I-1381

Floods

Photomosaic of channels and eroded landforms I-1652
Photomosaic Dromore crater
with breached ridge I-1068

Pathfinder

Map of Ares Vallis I-1551
Photomosaic of the flood channels
near landing site I-1343
Close-up photomosaic of landing site I-1345 & I-2311

(\$4.00, 3-4-week turn around)
United States Geologic Survey
Box 25286
Federal Center, Building 810
Denver, CO 80225
(800) 435-7627



NOTES

Mars Exploration Education and Public Outreach Program

Donna Shirley	Manager, Mars Exploration Program (NASA/JPL)
Dr. Cheick Diarra	Manager, Mars Exploration Education and Public Outreach Program (NASA/JPL)
Dr. Meredith Olson	Mars Exploration Program Educator (Seattle Country Day School)
Daniel Barstow	Project Director (TERC)
Christopher Randall	Curriculum Developer (TERC)
Hope Schauer	Illustration and Layout

These curriculum materials were developed for JPL's Mars Exploration Education and Public Outreach Program, which is part of NASA's Mars Exploration Program. The work is funded by NASA's Jet Propulsion Laboratory (JPL) which has the overall responsibility for the Mars Exploration Program.

These curriculum materials were developed through a sub-contract to TERC, Inc., a non-profit educational research and development company. The materials have been field-tested by teachers and reviewed by scientists. New versions of the materials will be released periodically, incorporating new discoveries about Mars and improvements based on teacher feedback.

For information about materials or the Mars Exploration Education Program please contact:

Dr. Cheick Diarra
Mars Exploration Education and Public Outreach Program
Jet Propulsion Laboratory
4800 Oak Grove Drive
Pasadena, CA 91109
818-354-6111

- Copyright ©1996, California Institute of Technology. ALL RIGHTS RESERVED
- Government Sponsorship acknowledged under contract NASA7-1260
- MARS PATHFINDER and MARS GLOBAL SURVEYOR are trademarks of the California Institute of Technology, Jet Propulsion Laboratory

Module Titles	Getting Started	Grand Canyon of Mars	Pathfinder Landing Site	Volcanoes	Mars Pathfinder	Mars Global Surveyor
TEACHER MATERIALS	Teacher's Guide	Teacher Handbook	Teacher Handbook	tba	tba	tba
STUDENT MATERIALS	Student Guidebook	Grand Canyon of Mars Image Set	Pathfinder Landing Site Image Set	tba	tba	tba